

# DENON<sup>®</sup>

## DP-3000NE

Direct Drive Turntable

# Owner's Manual

Front

Rear



|                                 |          |
|---------------------------------|----------|
| <b>Cautions on handling</b>     | <b>3</b> |
| About care                      | 3        |
| About condensation              | 3        |
| About lubricating               | 3        |
| <b>Accessories</b>              | <b>4</b> |
| <b>Part names and functions</b> | <b>6</b> |
| Front                           | 6        |
| Rear                            | 8        |

## Preparations

|  |           |
|--|-----------|
| <b>Assembly</b>                        | <b>10</b> |
| Mounting the platter                   | 11        |
| Mounting the counterweight             | 11        |
| Mounting the cartridge                 | 12        |
| Mounting the head shell                | 14        |
| Attaching the dust cover               | 15        |
| Mounting the subweight                 | 15        |
| <b>Adjustments</b>                     | <b>16</b> |
| Adjusting the height of the insulators | 16        |
| Adjusting the stylus pressure          | 17        |
| Adjusting anti-skating                 | 20        |
| Adjusting the height of the tone arm   | 21        |

## Connections

|   |           |
|---|-----------|
| <b>Connecting amplifier that have a phono input</b> | <b>24</b> |
| <b>Connecting the power cord</b>                    | <b>25</b> |

## Playback

|                        |           |
|------------------------|-----------|
| <b>Record playback</b> | <b>26</b> |
| Record playback        | 26        |
| Stopping playback      | 28        |

## Tips

|  |           |
|--|-----------|
| <b>Contents</b>                              | <b>29</b> |
| <b>Troubleshooting</b>                       | <b>30</b> |
| Power does not turn on                       | 31        |
| Power cannot be turned off                   | 31        |
| No sound comes out                           | 31        |
| Hum noise is heard                           | 32        |
| Audio skips, scratches or is distorted       | 32        |
| Howling is produced                          | 33        |
| The tone arm stops moving halfway            | 33        |
| The platter does not rotate at the set speed | 33        |

## Appendix

|                       |           |
|-----------------------|-----------|
| <b>Specifications</b> | <b>34</b> |
|-----------------------|-----------|



## Cautions on handling

---

### About care

- Clean the cabinet and dust cover with the wiping cloth. Follow the instructions when using a chemical cleaner.
- Benzene, paint thinner or other organic solvents as well as insecticide may cause material changes and discoloration if brought into contact with the unit, and should therefore not be used.

### About condensation

If there is a major difference in temperature between the inside of the unit and the surroundings, condensation (dew) may form on the operating parts inside the unit, causing the unit not to operate properly. If this happens, let the unit sit for an hour or two with the power turned off and wait until there is little difference in temperature before using the unit.

### About lubricating



The motor does not require lubricating. Do not lubricate this unit.



Thank you for purchasing this Denon product. To ensure proper operation, please read this owner's manual carefully before using the product. After reading this manual, be sure to keep it for future reference.

## Accessories

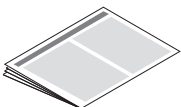
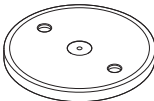
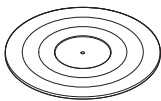
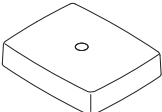
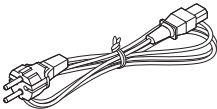
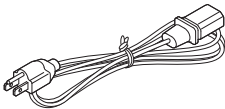
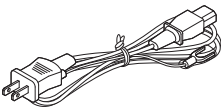
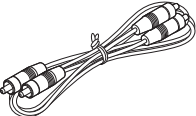
Check that the following parts are included with the product.

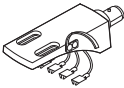
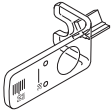
|  |  |  |   |
|--|--|--|---|
|  <p>Quick Start Guide</p> |  <p>Safety Instructions</p>               |  <p>Platter</p>                                  |  <p>Platter mat</p>                      |
|  <p>Dust cover</p>        |  <p>Power cord<br/>(for Europe model)</p> |  <p>Power cord<br/>(for North America model)</p> |  <p>Power cord<br/>(for Japan model)</p> |
|  <p>Audio cable</p>       |  <p>Earth wire</p>                        |  <p>Head shell<br/>(with lead wire)</p>          |  <p>Overhang gauge</p>                   |



**Screw set for mounting a cartridge**

- Screws (short/medium/long): 2 each
- Nuts: 2
- Washers: 2

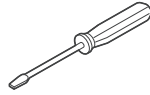
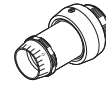
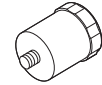
**Screwdriver****Counterweight****Subweight****45 rpm adaptor****Cartridge spacers**

# Part names and functions

## Front

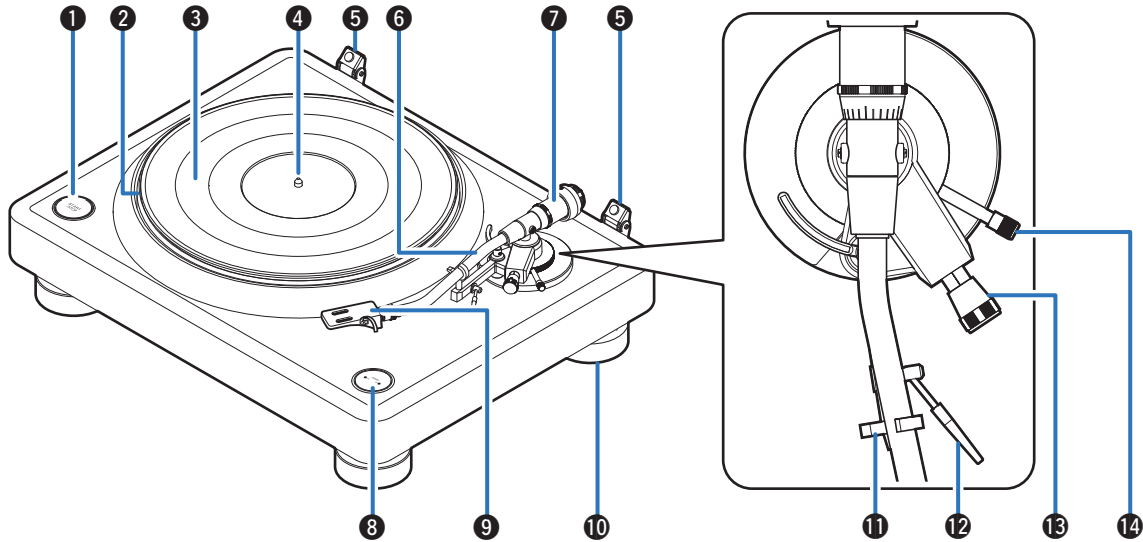

For details, see the next page.

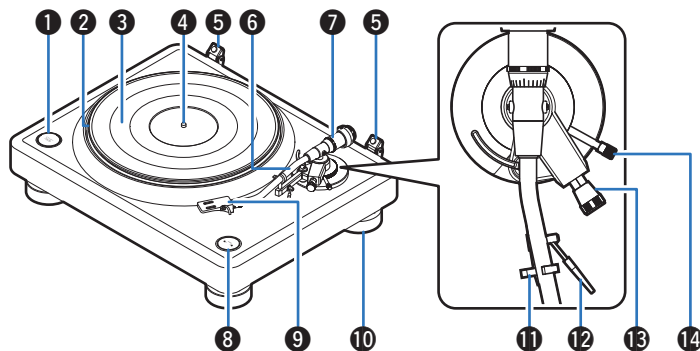

**1 START/STOP button**

Starts and stops the platter. (☞ p. 26)

**2 Platter**

Attached by mounting on the center spindle on the main unit.  
(☞ p. 11)

**3 Platter mat**

Mounted on top of the platter. (☞ p. 11)

**4 Center spindle**

Place the platter and records so that it comes out through the center.

**5 Hinge for attaching the dust cover**

Used to attach the included dust cover. (☞ p. 15)

**6 Tone arm**

- The counterweight is mounted on the back. (☞ p. 11)
- The head shell is attached to the tip. (☞ p. 14)
- The sub weight is mounted on the back. (☞ p. 15)

**7 Counterweight**

Attached to the back of the tone arm to adjust stylus pressure.

- “Mounting the counterweight” (☞ p. 11)
- “Adjusting the stylus pressure” (☞ p. 17)

**8 SPEED 33/45 button**

Set the correct speed for the record you are playing. (☞ p. 26)

**9 Head shell**

Mount a commercial cartridge to the head shell and then mount the head shell at the tip of the tone arm. (☞ p. 12)

**10 Insulator**

The height of the insulator can be adjusted. (☞ p. 16)

**11 Armrest**

Rest the tone arm here when it is not in use for record playback.

**12 Lifter lever**

Raises and lowers the tone arm. Lowering the lever slowly lowers the tone arm to place the stylus without damaging it or the record to be played. (Factory default setting: lowered position)

**13 Anti-skating knob**

Adjusts anti-skating. (☞ p. 20)

**14 Arm height adjustment knob**

Adjust the height of the tone arm according to the cartridge and head shell you are using. (☞ p. 21)

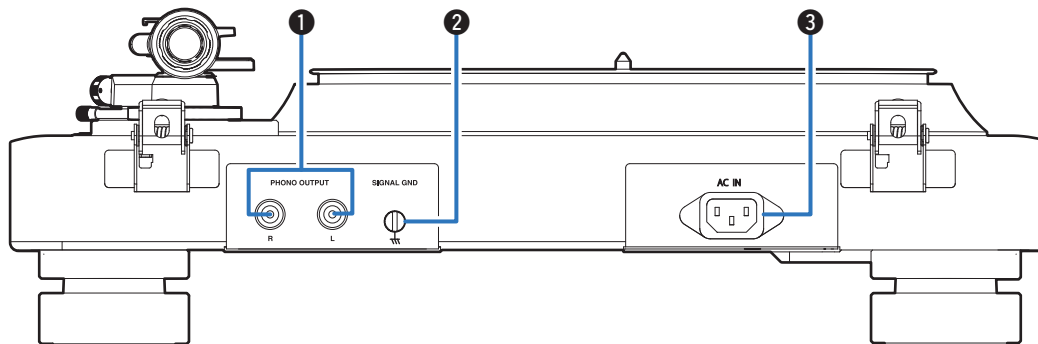

## Rear

**1 PHONO OUTPUT connectors**

Connect equipment such as an amplifier with a PHONO input terminal. (☞ p. 24)

**2 SIGNAL GND terminal**

Use the included earth wire, even when connecting this unit to amplifiers with grounded connections. (☞ p. 24)

**3 AC inlet (AC IN)**

Used to connect the power cord. (☞ p. 25)





## ■ Contents

### Assembly

---

|                            |    |
|----------------------------|----|
| Mounting the platter       | 11 |
| Mounting the counterweight | 11 |
| Mounting the cartridge     | 12 |
| Mounting the head shell    | 14 |
| Attaching the dust cover   | 15 |
| Mounting the subweight     | 15 |

### Adjustments

---

|  |    |
|--|----|
| Adjusting the height of the insulators | 16 |
| Adjusting the stylus pressure          | 17 |
| Adjusting anti-skating                 | 20 |
| Adjusting the height of the tone arm   | 21 |



## Assembly

Mount these included parts on the main unit before use.

Make sure to perform setup on a stable, even surface to prevent the influence of vibration or slanted angles on record playback.

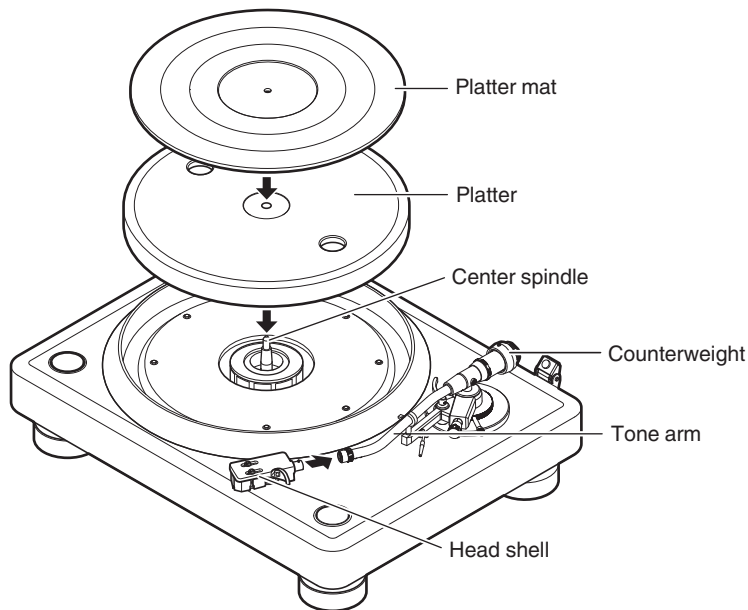

### NOTE

- Make sure the power cord is not connected from this unit to a wall socket during assembly.



## Mounting the platter

- 1 Mount the hole in the center of the platter on the center spindle.

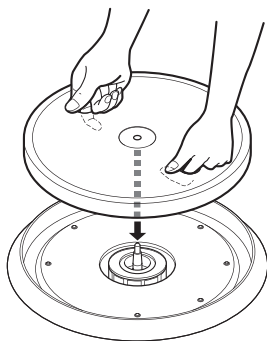

### NOTE

- Make sure there are no foreign objects around the center spindle before mounting the platter.
- The platter is heavy. Handle it with care.
- Take care not to get your fingers caught when mounting.

- 2 Mount the platter mat on the platter.



- Mount the mat with the side featuring the DENON logo facing down.

## Mounting the counterweight

- 1 Insert the counterweight into the shaft on the back of the tone arm, and turn it in the direction of the arrow while gently pushing it.

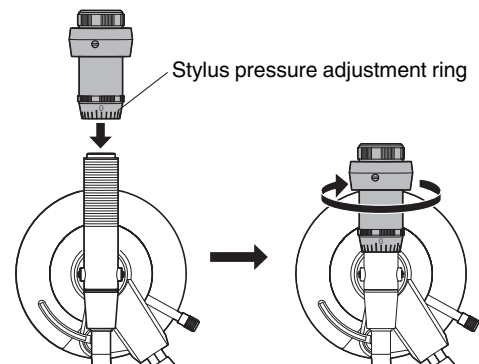

- Mount the counterweight so that its stylus pressure adjustment ring is facing the front.

### NOTE

- It should be mounted carefully to avoid applying excessive force because the thread of the counterweight is delicate.



## Mounting the cartridge

### 1 Attach the head shell to the cartridge (not included) loosely.

- Refer to the display or manual of the cartridge you are using and ensure that the lead wire is correctly connected to the terminal of the cartridge.
- To adjust to overhang, temporarily fix the cartridge so that it can be moved.

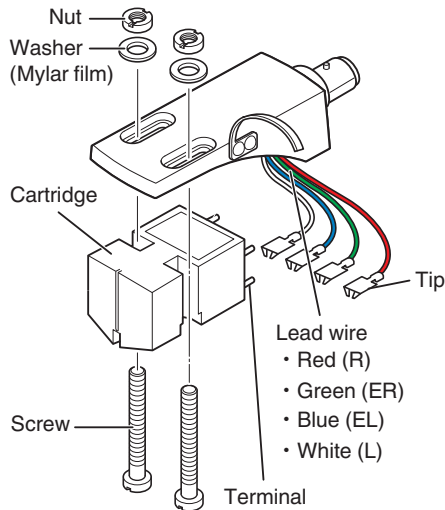

#### NOTE

- Use the included screws, nuts, washers and screwdriver.
- Do not touch the stylus.



- If the lead wire on the head shell is disconnected, connect the tip of the lead wire to the terminal, as shown below.
- The included lead wires can be replaced with commercially available lead wires.

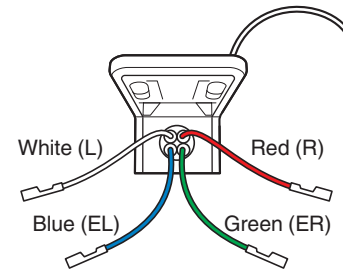

## 2 Adjust the overhang and then securely fasten the cartridge to the head shell.

- ① Mount the overhang gauge (included) to the head shell.

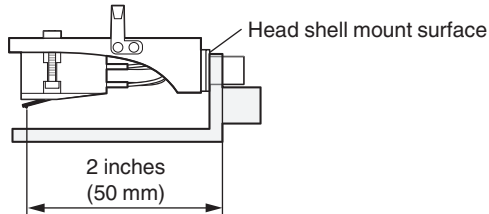

- ② Adjust the position of the cartridge so that the stylus is at the 2 inches (50 mm) point of the overhang gauge.
- 2 inches (50 mm) : This is the distance at which the stylus tip traces the left and right channels with optimum balance according to the positioning of the platter and tone arm. (overhang value)

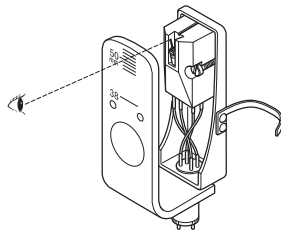

- ③ Tighten the screws with a screwdriver to secure the cartridge to the head shell.

### NOTE

- Mount the cartridge with no tilt or floating so that the stylus tip can trace the groove on a record correctly.

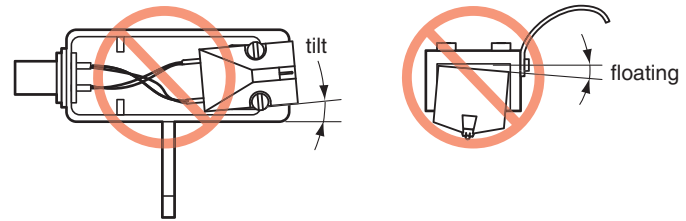

## Mounting the head shell

### 1 Insert the head shell into the tip of the tone arm.

- Insert the head shell with its guide pin facing up and aligned with the hole on the top of the tone arm.

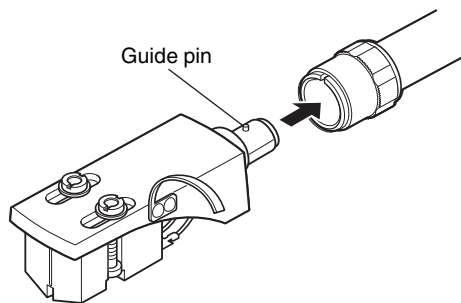

### 2 Turn the lock nut in the direction of the arrow to secure the head shell.

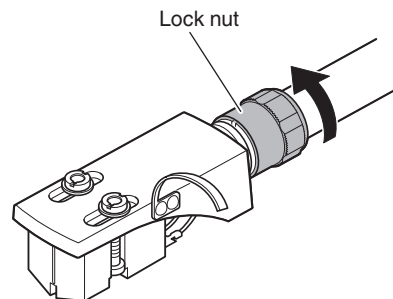

#### NOTE

- Do not touch the stylus.
- Keep the head shell and the tone arm terminal clean. If they are dirty, this may affect the sound quality. Regular cleaning is recommended.

## Attaching the dust cover

- 1 Insert the edges of the hinges on the main unit into the hinge slots of the dust cover.

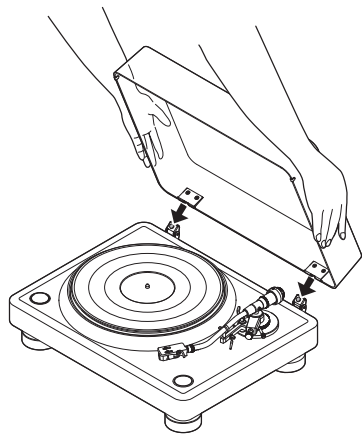

- To remove the dust cover, open the dust cover all the way and then pull it in the opposite direction to that indicated by the arrows.

## Mounting the subweight

If your cartridge and head shell are too heavy to keep the tone arm parallel to the record with the counterweight alone, attach the included subweight to the tone arm to keep it balanced.

- 1 Mount the subweight behind the counterweight by inserting it in the screw hole at the back of the tone arm.

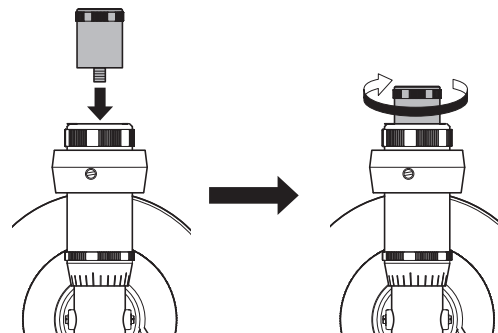

- Refer to "Suitable cartridge weight" (👉 p. 35) for details on the weight range of cartridges compatible with each of the weights.



# Adjustments

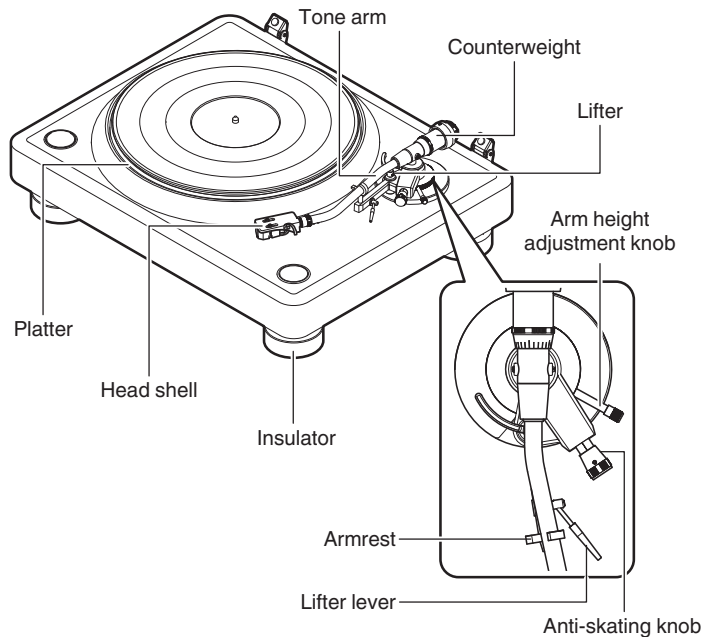

## Adjusting the height of the insulators

- 1 Turn the insulators to adjust their height so that the turntable is placed level.

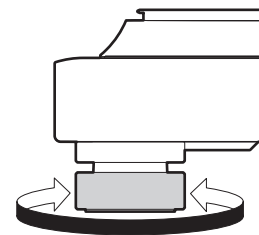

Increases the height

Reduces the height

### NOTE

- Do not overtighten the insulators as overtightening may result in damage.



- A commercial spirit level can be used for more accurate adjustment.

### NOTE

- Make sure the power cord is not connected from this unit to a wall socket when performing adjustments.





## Adjusting the stylus pressure

To enable the record stylus to follow the grooves of the record and pick up sound (vibrations), it is necessary to apply a constant pressure (stylus pressure) to the record from the stylus tip. A suitable stylus pressure value is specified for each cartridge. If the stylus pressure is higher or lower than the specified value, not only will the record playback sound be distorted and the stylus jump, but the record stylus may wear out faster and the record may become damaged. Therefore, make sure to adjust the stylus pressure to the suitable value.

### 1 Pull the anti-skating knob in the direction of the arrow.

This turns the anti-skating function off.

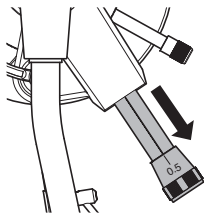

### 2 Lower the lifter lever.

### 3 Remove the tone arm from the arm rest.

### 4 Holding the finger lift of the headshell, move the tone arm over the platter.

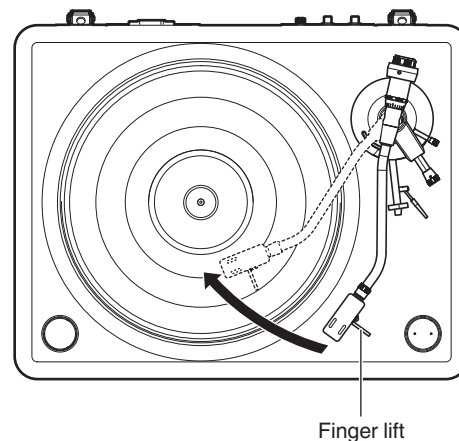

#### NOTE

- For a cartridge with a removable stylus cover, remove the stylus cover.



## 5 Turn twist the counterweight so that the tone arm is floating parallel to the platter.

- Perform adjustment by turning the counterweight gradually while periodically removing your hand to check the position.

Keep it parallel

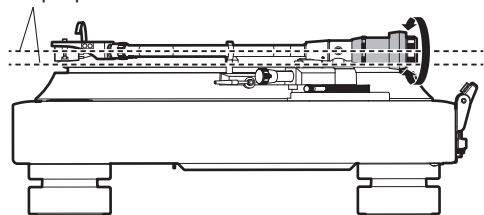

### NOTE

- Make sure the stylus does not touch the platter mat or the main unit.



- Adjustments can also be made by sliding part of the counterweight. Loosen the counterweight screw with the included screwdriver and slide the counterweight. After adjusting, tighten the screw to secure the counterweight.

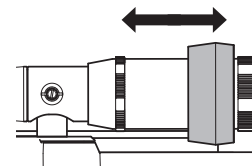
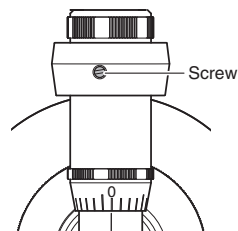

- If your cartridge and head shell are too heavy to keep the tone arm parallel to the record with the counterweight alone, attach the included subweight to the tone arm. (👉 p. 15)



**6** Return the tone arm to the armrest.

**7** Holding the counterweight with a finger so that it does not move, turn the stylus pressure adjustment ring so that its "0" mark is lined up with the line on the tone arm.

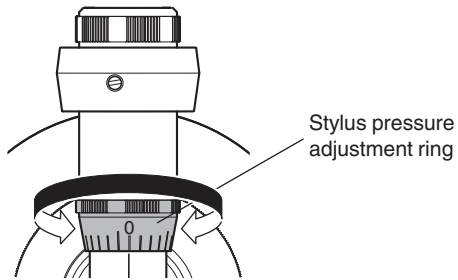

**8** Turn the counterweight in the direction of the arrow to set the right cartridge stylus pressure.

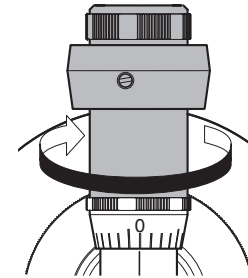

- Refer to the manual of the cartridge you are using for details on the right cartridge stylus pressure.



## Adjusting anti-skating

Anti-skating adjustment is performed to counter the force which pulls the stylus tip inside due to the record rotation.

- 1 Turn the anti-skating knob and set the same number as the cartridge stylus pressure.**

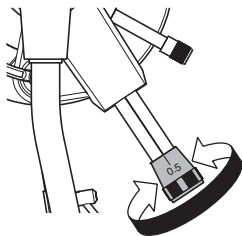

- 2 Push the anti-skating knob in the direction of the arrow.**  
This turns the anti-skating function on.

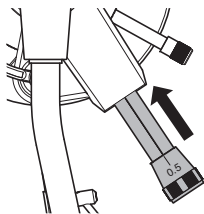

- If the stylus pressure of your cartridge is higher than 3.0 g , set "3".
- This will not affect the sensitivity of the arm because the anti-skating function of this unit is performed by a magnetic system that does not come into contact with the shaft of the tone arm.



## Adjusting the height of the tone arm

Depending on the cartridge or head shell you are using, the tone arm may not be parallel to the record when the stylus touches the record. If this happens, adjust the height of the tone arm until it is parallel to the record. This needs to be properly adjusted so that the stylus of the cartridge will trace the grooves of the record correctly.

- 1 Turn the arm height adjustment knob counterclockwise to unlock it.

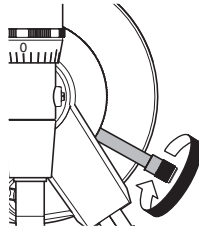

- 2 Use the arm height adjustment knob to turn the base of the tone arm and adjust the height.

- Adjust until the tone arm is parallel to the top of the record.

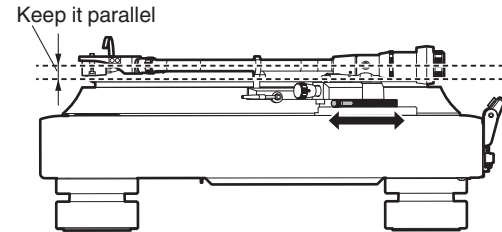

### 3 Turn the arm height adjustment knob clockwise to lock it.

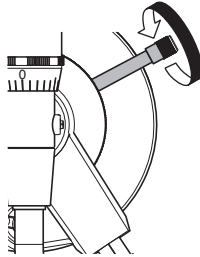

- The tone arm height can be adjusted from 0 to 0.35 inches (9 mm).
- If the cartridge height is too small, it may not be possible to make the tone arm parallel to the record by adjusting the height of the tone arm. If this happens, put the included cartridge spacers between the head shell and the cartridge and adjust until the tone arm is parallel to the record.



## ■ Contents

|  |    |
|--|----|
| Connecting amplifier that have a phono input | 24 |
| Connecting the power cord                    | 25 |

### NOTE

- Do not plug in the power cord until all connections have been completed.
- Do not bundle power cords together with connection cables. Doing so can result in humming or noise.



## Connecting amplifier that have a phono input

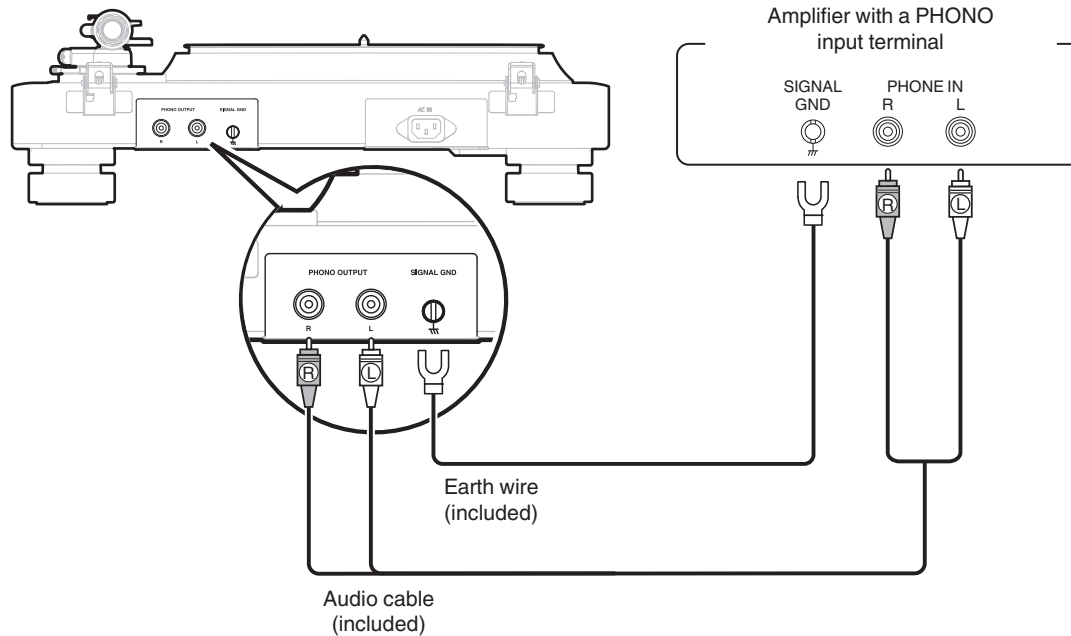

- If a device connected to this unit has an earth terminal, connect the earth wire (included) to the earth terminal of this unit (SIGNAL GND). This may reduce noise during playback.
- Red and black rubber rings are attached to the audio cable plugs to distinguish between the left and right sides. Reattach the rings if they come off.





## Connecting the power cord

After completing all the connections, insert the power plug into the power outlet.

A power cord for each region is included. Use the power cord for your region.

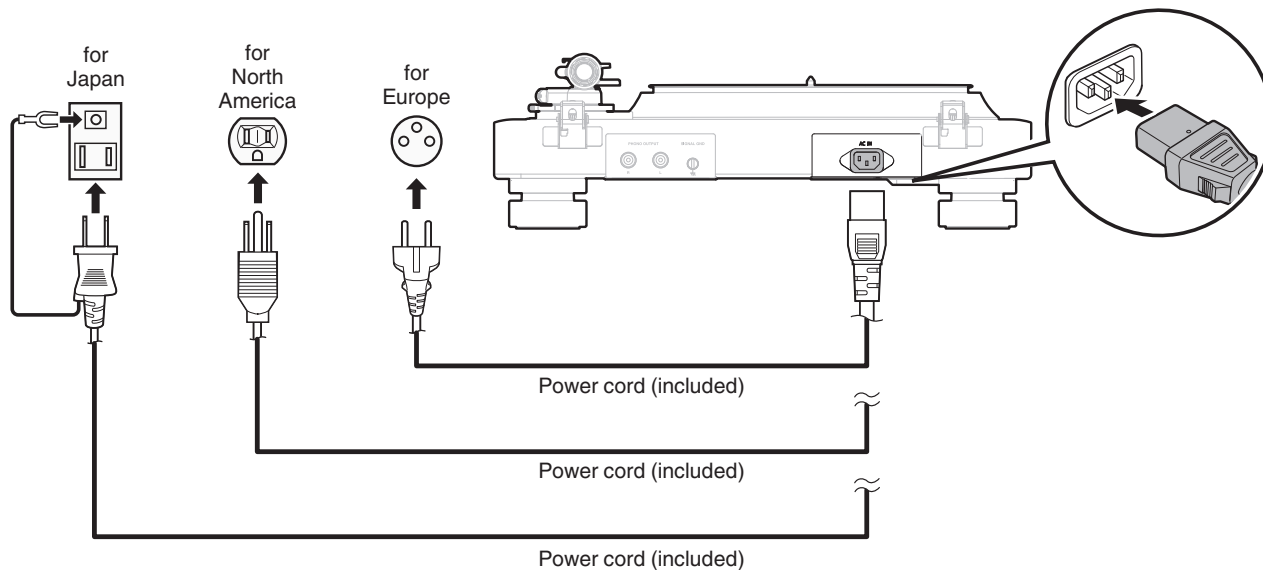

### NOTE

- This unit turns on when the power cord connected to the unit is plugged in to a power outlet.
- When leaving home for long periods of time or when going on vacation, unplug the power cord from the power outlet.



# Record playback

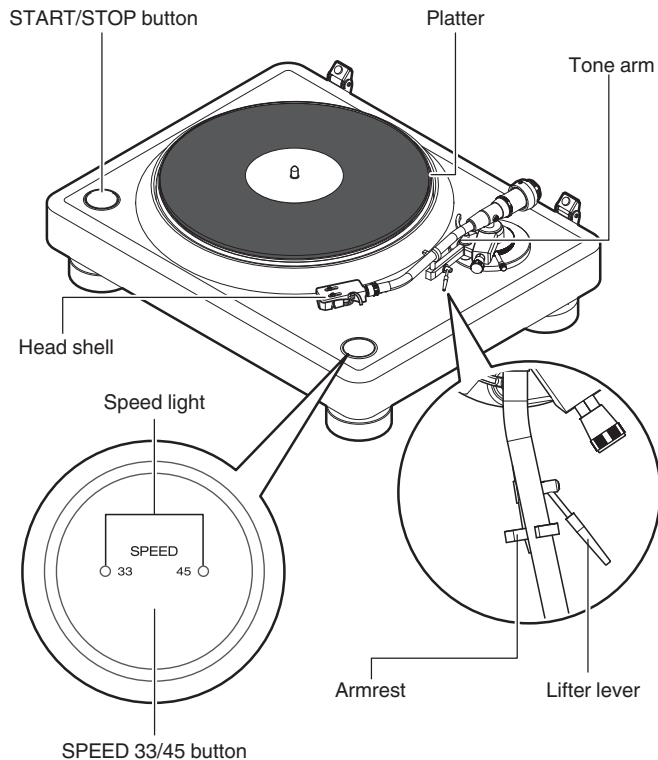

## Record playback

### 1 Place a record on the platter.



- For EP (“doughnut”) records, insert the included 45 rpm adapter onto the center spindle.
- The adapter for 45 rpm records can also be used as a stabilizer.

### 2 Press the SPEED 33/45 button to set the right platter speed for the record you are playing.

The button toggles between 33 1/3 rpm and 45 rpm. The current speed is displayed in the speed light.



- This unit also supports 78 rpm records. While pressing the SPEED 33/45 button, press the START/STOP button. Both speed lights turn on and the speed changes to 78 rpm.
- The record rpm is normally indicated on the jacket or label of the record.
- After pressing the SPEED 33/45 button, the speed light will turn on for approximately 20 seconds.
- The speed light corresponding to the set speed will turn on when the platter is turning.
- After the platter stops, the speed light will turn off after approximately 20 seconds.

### 3 Press the START/STOP button.

The platter will start turning.



- 4** Lift the lifter lever and remove the tone arm from the arm rest.

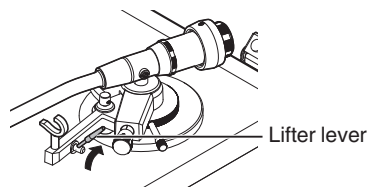

- 5** Grip the finger lift, and move the stylus tip directly above the start position of the track to play.

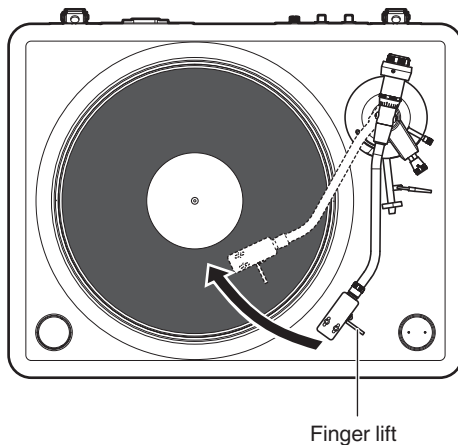

- 6** Lower the lifter lever.

The tone arm slowly lowers, and playback starts when the stylus tip reaches the record.

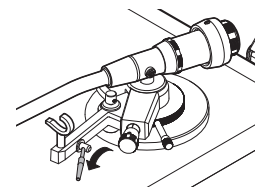

- Be careful not to scratch records.
- Observe the following during playback.
  - Do not touch the tone arm or platter.
  - Do not disconnect the power.
  - Make sure this unit is not subjected to vibration or impact.
- Do not change the record until the platter has completely stopped.
- Do not apply pressure with your hand to stop the platter while it is turning. Doing so creates internal heat which can lead to equipment failure or fire.



## Stopping playback

- 1 Raise the lifter lever.**  
Raise the tone arm to remove the stylus from the record.
- 2 Holding the finger lift of the headshell, return the tone arm to the armrest.**
- 3 Lower the lifter lever.**
- 4 Press the START/STOP button.**  
The platter stops.



# Contents

---

## ■ Troubleshooting

|  |    |
|--|----|
| Power does not turn on                       | 31 |
| Power cannot be turned off                   | 31 |
| No sound comes out                           | 31 |
| Hum noise is heard                           | 32 |
| Audio skips, scratches or is distorted       | 32 |
| Howling is produced                          | 33 |
| The tone arm stops moving halfway            | 33 |
| The platter does not rotate at the set speed | 33 |



## Troubleshooting

---

If a problem should arise, first check the following:

1. Are the connections correct?
2. Is the set being operated as described in the owner's manual?
3. Are the other devices operating properly?

If this unit does not operate properly, check the corresponding symptoms in this section.

If the symptoms do not match any of those described here, consult your dealer as it could be due to a fault in this unit. In this case, disconnect the power immediately and contact the store where you purchased this unit.



## Power does not turn on

### Power is not turned on.

- Check whether the power plug is correctly inserted into the power outlet. (👉 p. 25)

## Power cannot be turned off

### Power cannot be turned off.

- This unit does not have a power switch. When leaving home for long periods of time or when going on vacation, unplug the power cord from the power outlet.

## No sound comes out

### No sound is produced. Or sound is distorted.

- Check the connections for all devices. (👉 p. 23)
- Insert connection cables all the way in.
- Check that input connectors and output connectors are not reversely connected.
- Check cables for damage.
- Check the amplifier's functions and controls and adjust as necessary.
- Make sure the cartridge is correctly attached. (👉 p. 12)



## Hum noise is heard

### Hum noise is heard.

- Check that the earth wire of the audio cable is connected to the amplifier. (👉 p. 24)
- Check that the audio cable is connected to the amplifier correctly. (👉 p. 24)
- Check that the head shell is securely fastened to the tone arm. (👉 p. 14)

## Audio skips, scratches or is distorted

### Audio skips, scratches or is distorted.

- The correct stylus pressure is not applied. Adjust to the correct pressure. (👉 p. 17)
- Make sure there are no scratches on the record.
- Make sure the record is not warped.
- Make sure there is no dirt or dust on the stylus or the record.





## Howling is produced

### Howling is produced.

- This unit and speaker are too close together. Move the speaker away from this unit.
- This unit is in an unstable position. Install in a stable, level location.
- Playback volume is too loud. Adjust the volume of the connected amplifier to the appropriate level.

## The tone arm stops moving halfway

### The tone arm not tracking during playback.

- Make sure there are no scratches on the record.
- Make sure nothing is obstructing the tone arm.

## The platter does not rotate at the set speed

### The platter does not rotate at the set speed.

- The speed light blinks continuously when the platter is not rotating at the set speed. Unplug and reinsert the power cord, then press the START/STOP button again. If this does not resolve the problem, contact our customer service center.



# Specifications

---

## ■ Turntable section

|                               |   |
|-------------------------------|---|
| <b>Driving system:</b>        | Direct drive  |
| <b>Speed:</b>                 | 33 1/3 rpm, 45 rpm, 78 rpm                              |
| <b>Wow &amp; flutter:</b>     | Less than 0.06 % WRMS                                   |
| <b>Starting time:</b>         | Specified speed within 1.0 sec (for 33 rpm)             |
| <b>Starting torque:</b>       | 3.9 lb/in (4.5 kg/cm)                                   |
| <b>Platter:</b>               | Aluminum die-cast, diameter 12 inches (305 mm) diameter |
| <b>Motor:</b>                 | Brushless DC motor                                      |
| <b>Speed control system:</b>  | SVPWM control, Quartz lock                              |
| <b>Deviation of rotation:</b> | Within $\pm 0.5$ %                                      |
| <b>S/N ratio:</b>             | More than 70 dB   |



## ■ Tone arm section

|  |   |
|--|---|
| <b>Arm form:</b>                       | Static balance S-shaped pipe arm  |
| <b>Effective arm length:</b>           | 9.6 inches (244 mm)   |
| <b>Overhang:</b>                       | 0.55 inches (14 mm)   |
| <b>Tracking error:</b>                 | Within 2.5° (max)   |
| <b>Arm height adjustable range:</b>    | About 0.35 inches (9 mm)  |
| <b>Stylus pressure variable range:</b> | 2.5 g (24.5 mN) / per rotation<br>One step 0.1 g (0.98 mN)  |
| <b>Suitable cartridge weight:</b>      | Without sub weight<br>4 to 16 g<br>15 to 27 g (including the head shell with lead wire, screws, nuts and washers)<br>Using sub weight<br>14 to 26 g<br>25 to 37 g (including the head shell with lead wire, screws, nuts and washers) |
| <b>Head shell weight:</b>              | 11 g (including screws, nuts and washers)   |

## ■ General

|   |                          |
|---|--------------------------|
| <b>Operating temperature:</b>             | +5 °C - +35 °C           |
| <b>Power supply:</b>                      | AC 100 – 240 V, 50/60 Hz |
| <b>Power consumption:</b>                 | 4 W                      |
| <b>Power consumption in standby mode:</b> | Less than 0.3 W          |

For the purpose of improvement, the specifications and design are subject to change without notice.



■ Dimensions (Unit : in. (mm))

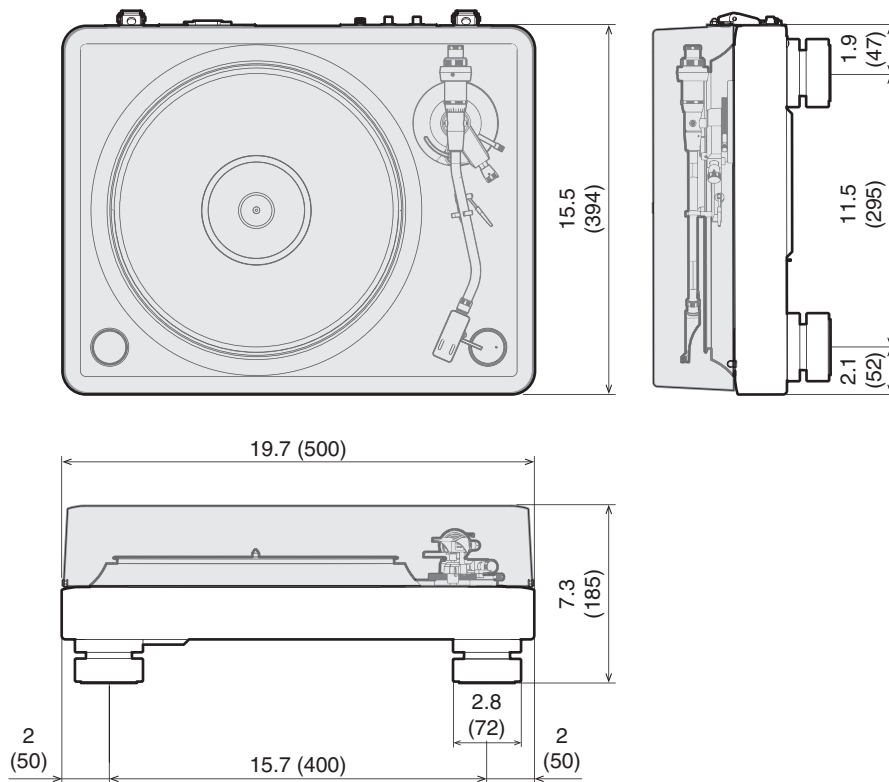

【Dust cover opened】

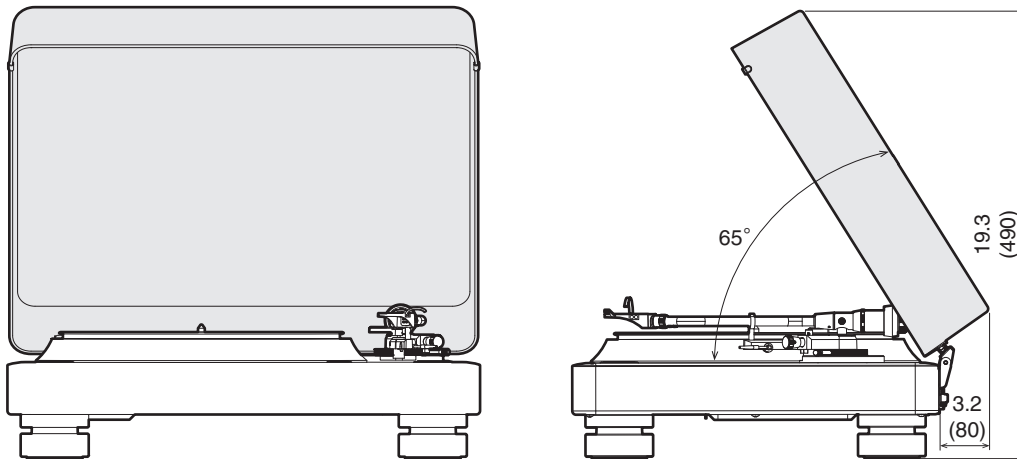

■ Weight: 40.8 lb (18.5 kg) (including the dust cover)

**DENON®**

[www.denon.com](http://www.denon.com)

3520 10915 00ASA

©2023 DEI Sales, Inc. All Rights Reserved.